

AM-EN2211S003(CL) SERIES

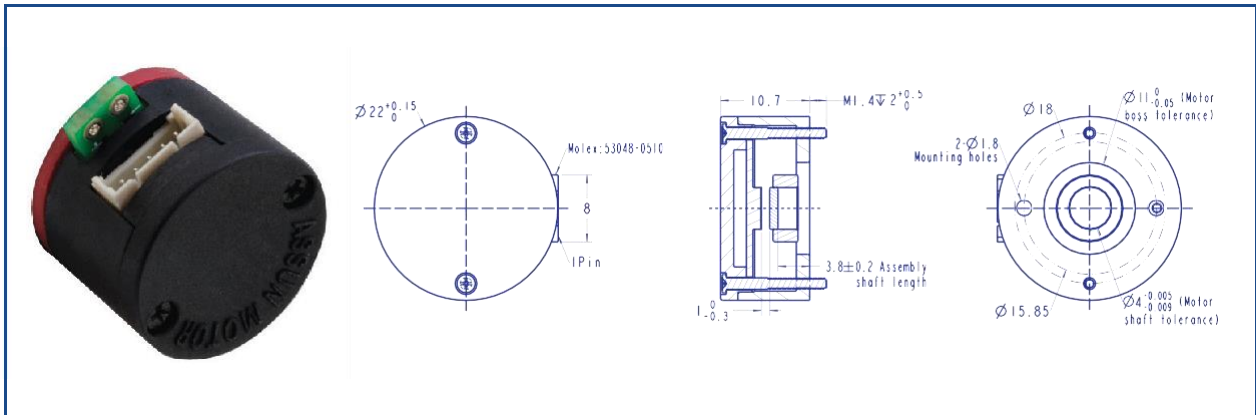

ELECTROMAGNETIC ENCODER

1) Parameters

Parameters/Models	AM-EN2211 S003-0032	AM-EN2211 S003-0064	AM-EN2211 S003-0128	AM-EN2211 S003-0256	AM-EN2211 S003-0512	AM-EN2211 S003-1024
Diameter	22	22	22	22	22	22
PPR/TURN	32	64	128	256	512	1024
Max Channels	3	3	3	3	3	3
Max Working Freq.(KHz)	20	40	100	180	360	512
Direction Signal	no	no	no	no	no	no
Drive (Differential Output)	no	no	no	no	no	no

2) Information

Technical Parameter		Suitable for motor size		Pin definition	Connection Diagram (CW)
Power Vcc	5V±5%	Suitable for shaft diameter	4.0; 5.0; 8.0	1. Vcc	
Vcc=5.0V Signal	TTL compatible	Suitable for shaft length	3.7~4.0	2. GND	
Operating Temperature	-25~85°C	Suitable for boss diameter	10.95~11.0	3. Channel A	
Inertia (max)	0.015 g.cm ²	Suitable for boss thickness	Maximum 1.0	4. Channel B	
Output Current, each channel	1.5mA(max)	Code wheel spacing	0.7~1.0	5. Channel Z (1/4 T)	
Weight	7.0 g	Other fixed size	Drawing		

3) Recommend Combination

Total Length of Geared Motor System :L _T =L ₁ +L ₂ +(L ₃ =10.7mm)					
L1:20GP	L1:24GP	L2:CL22	L1:36GP	L1:40GP	L2:CL35
18.8	22.2	32.2	39.6	46.8	70.5
23.6	27.4	42.0	48.6	58.3	
28.4	32.6		57.6	69.8	
L1:45GP		L2:CL35			
62.8		70.5			
74.8					

AM-EN2211S* Combination Scheme**

Recommended Gearbox:
Planetary Gearbox:
AM-20GP AM-40GP
AM-24GP AM-45GP
AM-36GP

Recommended Motor:
Coreless Motor:
AM-CL22**
AM-CL35**

For more combination specs, visit Assun Motor website.

Remarks: Clients can choose gearbox and motor to match with this encoder. Some combinations are listed here for reference.

ENCODER

Please tell us if there is vibration in application. Client should pay attention to the integrity and reliability of the transmitted signal.